

Service Schematics

NOKIA 6263

Introduction

RM-207

IMPORTANT:

This document is intended for use by authorized NOKIA service centers only.

“Service Schematics” was created with focus on customer care.
The purpose of this document is to provide further technical repair information for NOKIA mobile phones on Level 3/4 service activities.
It contains additional information such as e.g. “Component finder”.

Saving process time and improving the repair quality is the aim of this document.
It is to be used additionally to the service manual and other training or service information such as Service Bulletins.

While every endeavour has been made to ensure the accuracy of this document, some errors may exist. If the reader finds any errors, NOKIA shall be notified in writing.

Please send E-Mail to: TrainingAndVendor.Development@nokia.com

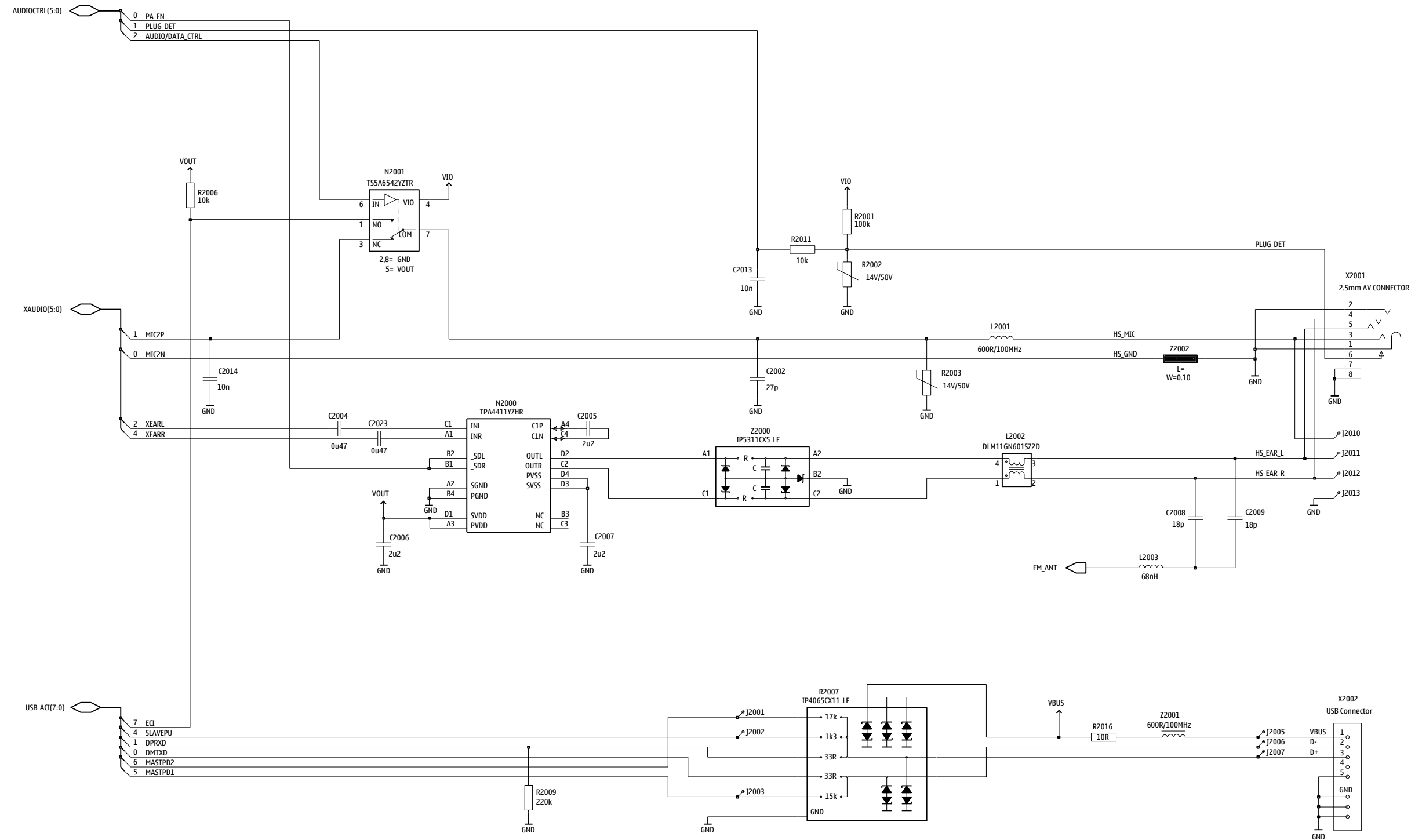

Table of Content

Front page	1
AV connector, USB connector	2
AVilma, Betty	3
RAP3GS, BTHFM, microSD, keyboard	4
Flip PWB	5
RF part	6
Component finder main PWB	7
Component finder flip PWB	8

Copyright © NOKIA

This material, including documentation and any related computer programs is protected by copyright, controlled by NOKIA. All rights are reserved. Copying, including reproducing, modifying, storing, adapting or translating any or all of this material requires the prior written consent of NOKIA. This material also contains company confidential information, which may not be disclosed to others without the prior written consent of NOKIA.



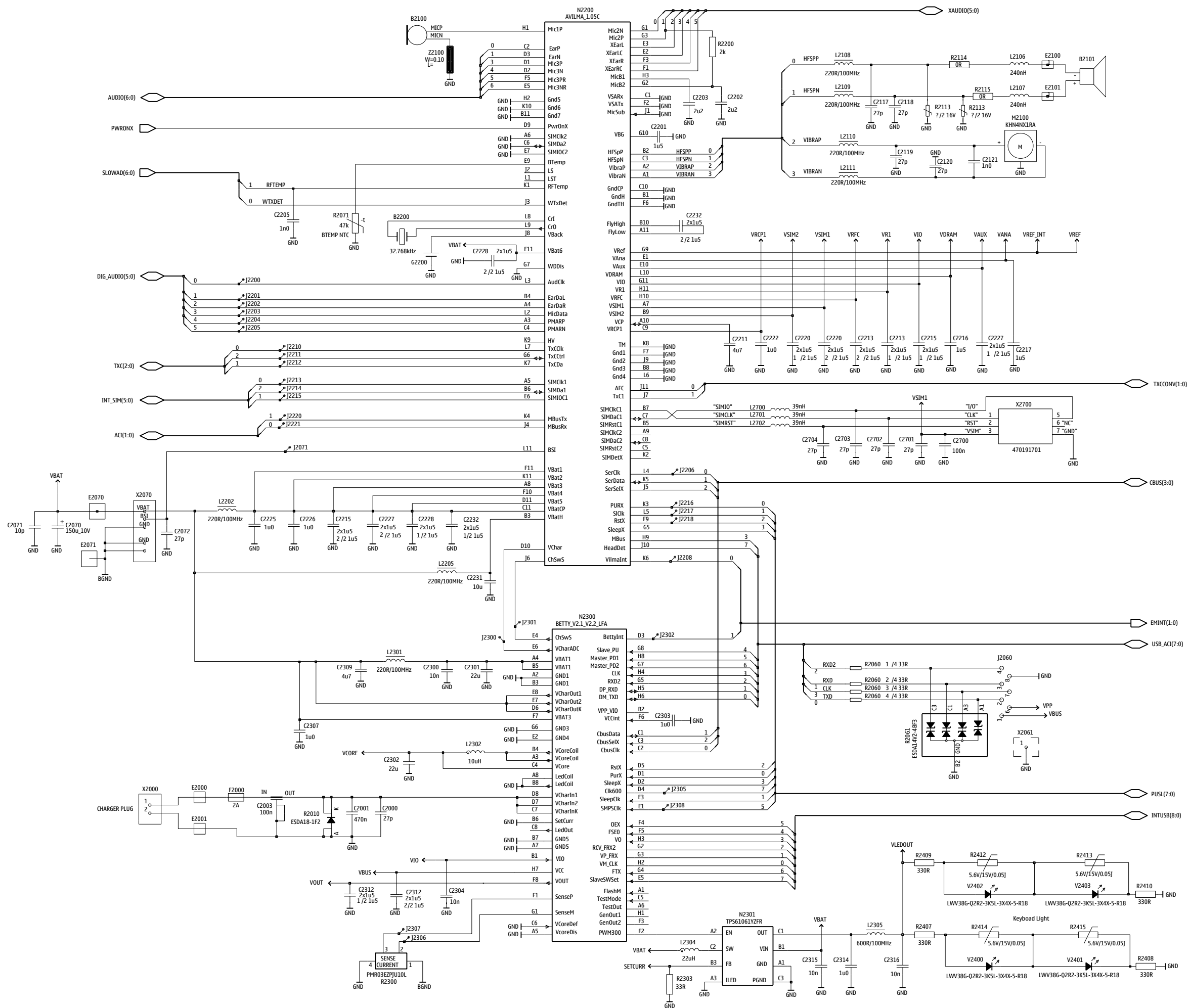

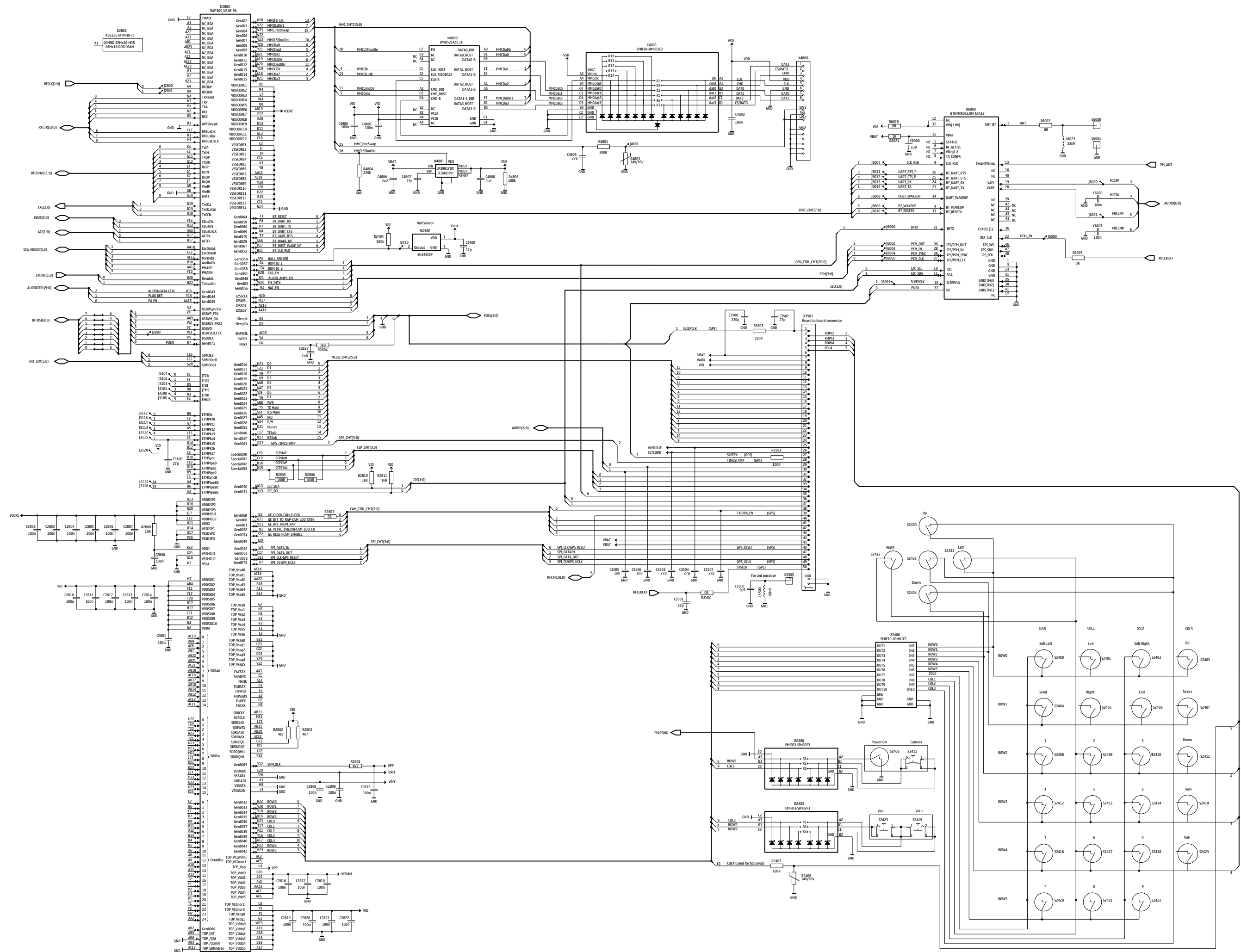

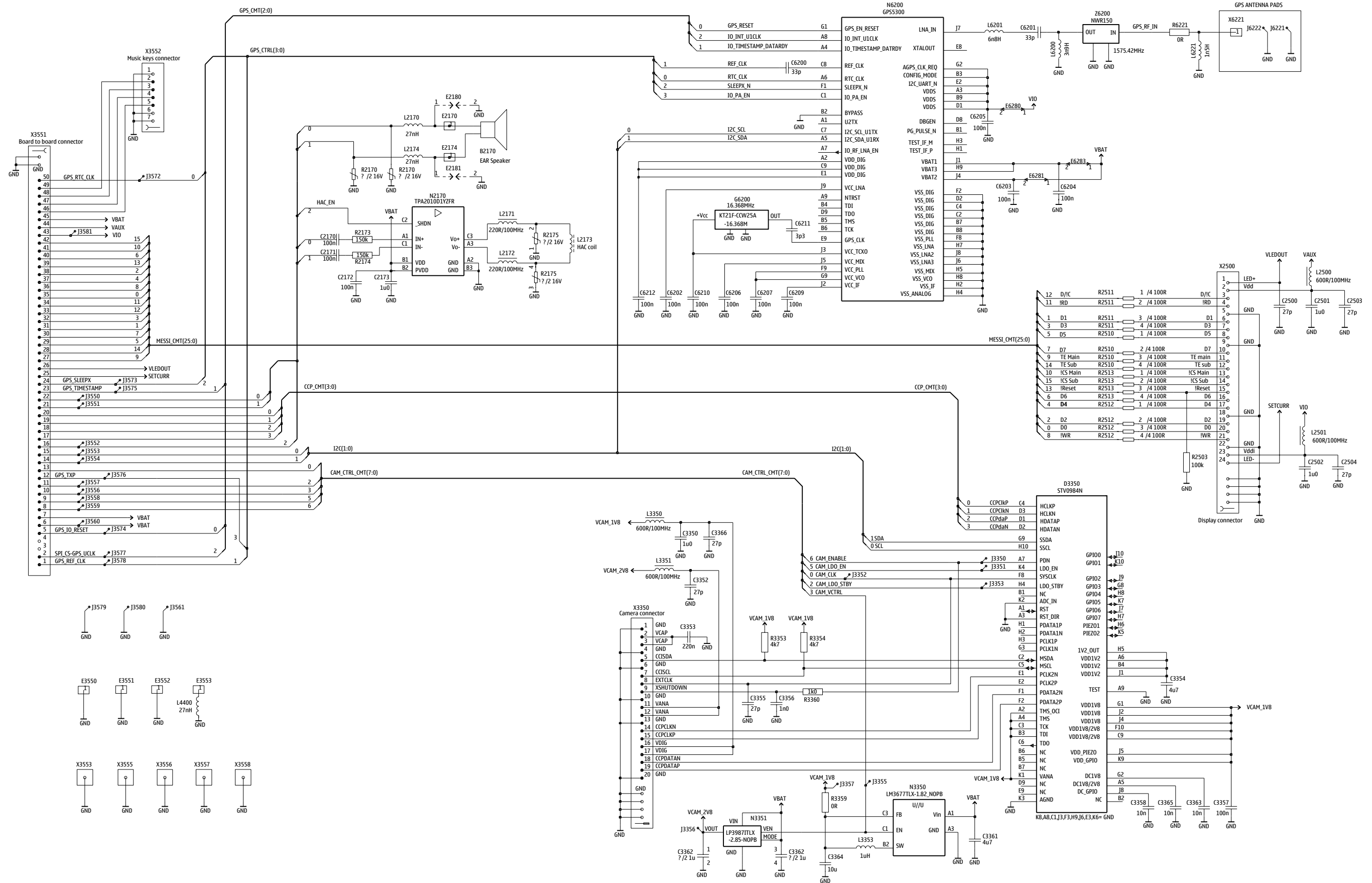

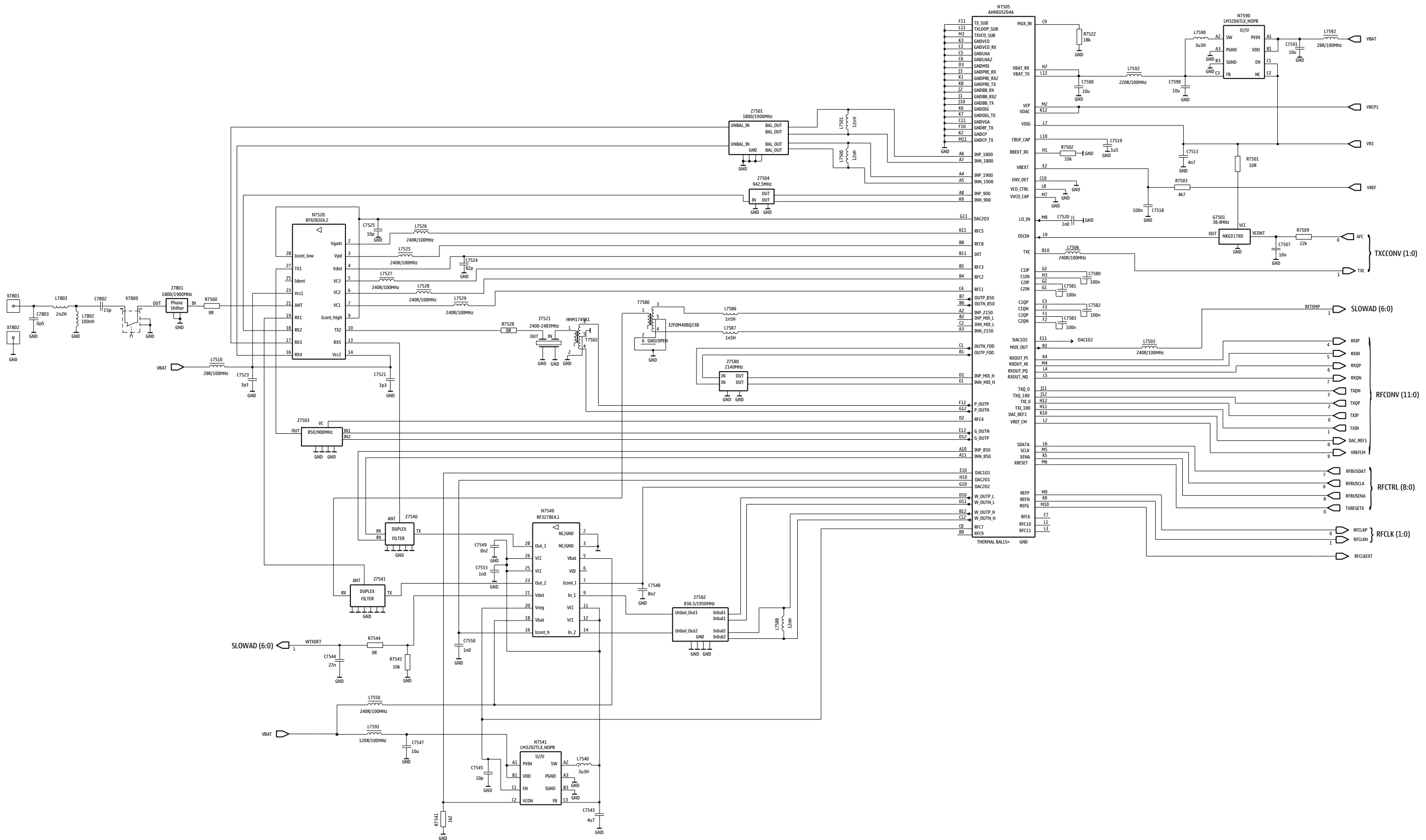

C	J3353	M3
C2170	K9	J3355 09
C2171	K9	J3356 N8
C2172	J9	J3357 N8
C2173	K9	J6221 P4
C2500	B9	J6222 P5
C2501	K9	L
C2502	K9	L2170 A7
C2503	L9	L2171 J9
C2504	L9	L2172 J9
C3350	N9	L2173 B3
C3352	N9	L2174 A7
C3353	N9	L2500 L9
C3354	P5	L2501 L9
C3355	P3	L3350 N9
C3356	O3	L3351 N9
C3357	P3	L3353 O3
C3358	P3	L4400 D3
C3361	O5	L6200 O3
C3362	N9	L6201 O3
C3363	P5	L6221 P3
C3364	O4	N
C3365	O3	N2170 J9
C3366	N8	N3350 O4
C6200	N4	N3351 N9
C6201	O3	N6200 N3
C6202	O3	R
C6203	N3	R2170 I9
C6204	O4	R2173 K9
C6205	N4	R2174 K9
C6206	O3	R2175 I9
C6207	N4	R2503 A8
C6209	N3	R2510 F9
C6210	N3	R2511 G9
C6211	N4	R2512 C9
C6212	N2	R2513 F9
D	R3353	O5
D3350	O4	R3354 O5
E	R3359	O4
E2170	B5	R3360 O3
E2174	B5	R6221 P4
E2180	C6	X
E2181	C5	X2500 B8
E3550	O2	X3350 O9
E3551	O9	X3551 M7
E3552	C9	X3552 H9
E3553	C3	X3553 M2
E6281	M2	X3555 F2
E6283	M2	X3556 M9
G	X3557	J9
G6200	O4	X3558 F9
J	X6221	P3
J3350	M3	Z
J3351	M3	Z6200 O4
J3352	M4	

